

3/4 Climbing Frame

Parts List:

12x 80mm Screws
10x 50mm Screws

Required Tools

Drill or Screwdriver
2 Adults are needed to assemble this product

1. Place the base on a flat level surface, place the 2 side panels onto the base, and lean together to form the triangle structure. Fix base to sides using 80mm Screws in the pre-drilled holes in each corner (4x 80mm screws total). Fix the Top Beam using 4x 50mm screws in the pre-drilled Holes.

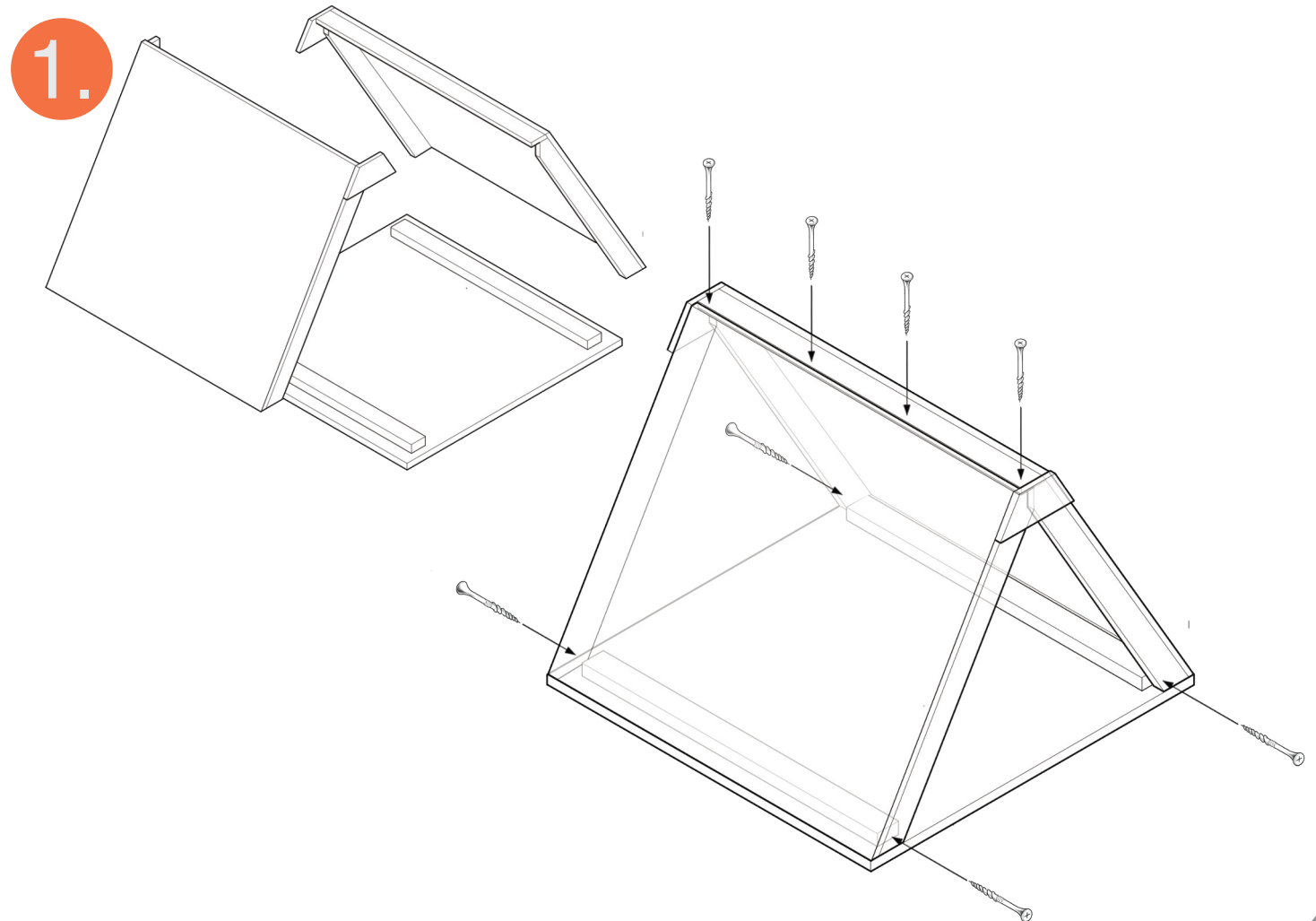

2. Fix the braces to the structure using 3x 50mm screws in the predrilled Holes, and repeat on opposite side. (6x 50mm screws total)

3. Inside the structure secure the rails to the side panels, using 4x 80mm screws in the pre-drilled holes on each rail (8x 80mm screws total)

